

PROPELLER SHAFT

2E

SECTION INDEX

	Page		Page
Driveline Vibration	2E-2	Specifications	2E-10
General	2E-1	Tools	2E-11
Lubrication	2E-8	Universal Joint Angle Measurement and Adjustment	2E-8
Propeller Shaft Service	2E-9	Universal Joint Service	2E-9

GENERAL

Jeep vehicles use tubular propeller shafts to transmit engine torque from the transfer case to the front and rear axles. Universal joints connect each shaft to the transfer case and axle yokes. A splined slip yoke is used at one end of each propeller shaft to compensate for variations in shaft length caused by suspension spring movement.

Because of the various driveline combinations available on Jeep vehicles, several different propeller shaft and universal joint designs are required.

Propeller Shaft Application

The front propeller shaft on Cherokee, Wagoneer and Truck models is connected to the axle yoke with a single cardan universal joint and to the transfer case yoke with a double cardan universal joint (fig. 2E-1).

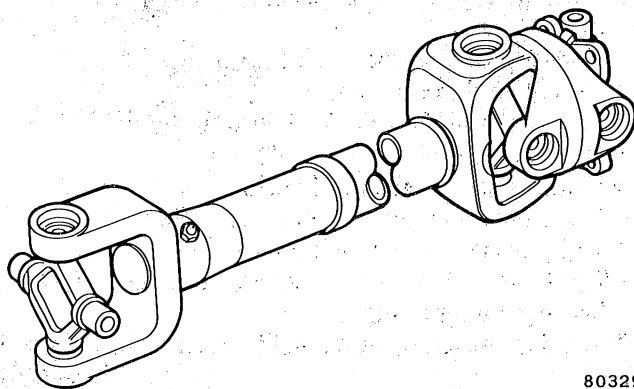

80329

Fig. 2E-1 Front Propeller Shaft Assembly—
Cherokee, Wagoneer and Truck Models

The front propeller shaft on CJ and Scrambler models is connected to both the axle and transfer case yokes with single cardan universal joints. A slip yoke is used at the axle end of the shaft (fig. 2E-2).

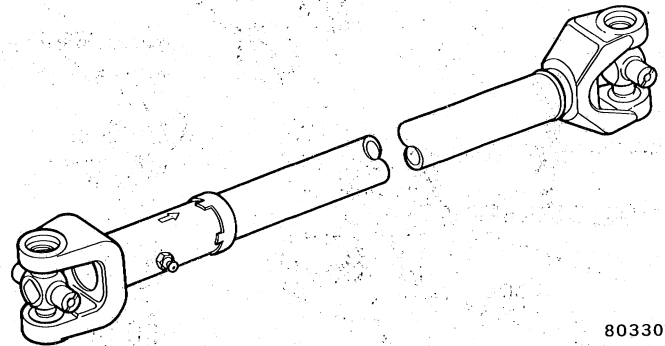

80330

Fig. 2E-2 Front Propeller Shaft Assembly—
CJ and Scrambler Models

The rear propeller shaft on Cherokee, Wagoneer and Truck models is connected to both the axle and transfer case yokes with single cardan universal joints. A slip yoke is used at the transfer case end of the shaft (fig. 2E-3).

The rear propeller shaft on CJ and Scrambler models is similar to the front shaft in appearance and construction. Single cardan universal joints connect the shaft to both the axle and transfer case yokes and the slip yoke is located at the transfer case end of the shaft.

Universal Joint Application

Two different design universal joints are used for the various driveline combinations: a single cardan joint and a double cardan joint.

Vibration caused by axle, transfer case, engine or suspension components may be the result of:

- Loose yoke retaining nut
- Excessive yoke runout
- Incorrect universal joint angle
- Bent, worn, broken, or loose torque reaction bracket or engine rear crossmember
- Damaged or loose suspension springs or suspension components
- Loose engine or transmission/transfer case support cushions or crossmembers, broken spring mounting

pad (on axle), broken spring center bolt, or damaged engine driven accessories or drive belts.

Driveline Vibration Diagnosis

If a driveline vibration condition should develop, do not initiate corrective procedures until the vibration source has been determined. This is important in avoiding unnecessary or ineffective repairs. The following Diagnosis and Repair (DARS) Charts will help to isolate the most common causes of driveline vibration:

Driveline Vibration Diagnosis and Repair (DARS) Charts

Note: Refer to Chapter A – General Information for details on how to use this DARS chart.

PROBLEM: DRIVE LINE VIBRATION

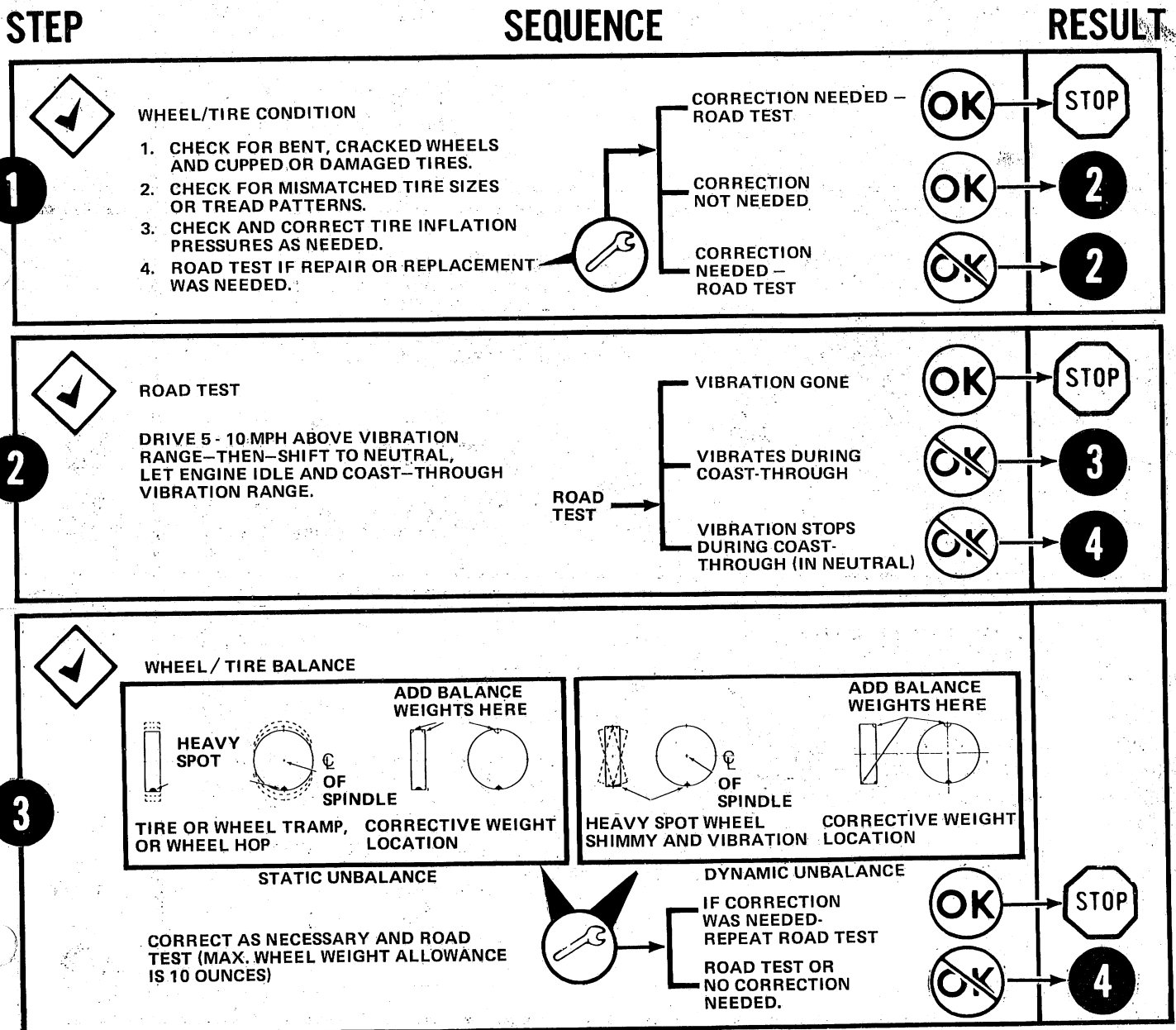

STEP

SEQUENCE

RESULT

4 CHECK TIRE RUNOUT

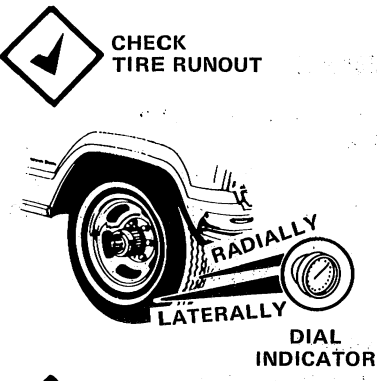

4 CHECK WHEEL RUNOUT

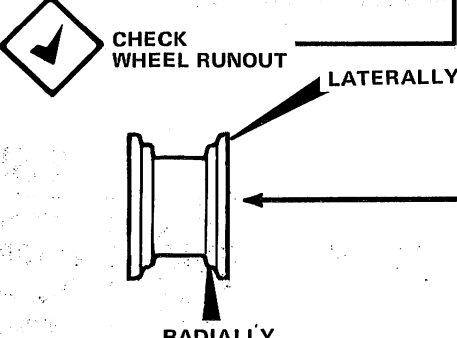

TIRE RADIAL RUNOUT:
 RADIAL TIRES - - - - - 0.080
 CONVENTIONAL TIRES - - - 0.105

TIRE LATERAL RUNOUT:
 ALL TIRES - - - - - 0.100

WHEEL RUNOUT:
 LATERAL/RADIAL - - - - 0.045

NO CORRECTION NEEDED → **OK** → **5**

CORRECTION NEEDED → ~~OK~~ → REPAIR OR REPLACE AS NECESSARY → **2**

ROAD TEST

5 CHECK FRONT PROPELLER SHAFT OPERATION

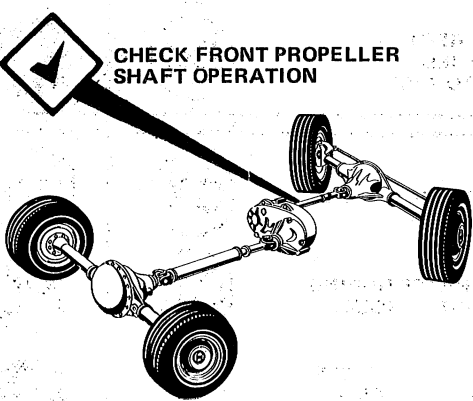

1. REMOVE REAR PROPELLER SHAFT (ALIGN MARK SHAFT AND AXLE YOKE FOR ASSEMBLY REFERENCE).
2. ROAD TEST WITH QUADRA-TRAC IN 4H-LOCK. ROAD TEST MODELS 208 AND 300 IN 4-H.

ROAD TEST **2** → VIBRATION GONE OR NOTICEABLY REDUCED → **OK** → **6**

ROAD TEST **2** → NO CHANGE IN VIBRATION LEVEL → ~~OK~~ → **10**

6 CHECK REAR PROPELLER SHAFT CONDITION



WORN, BINDING
BRINELLED
U-JOINTS

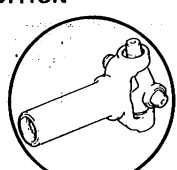

WORN, LOOSE
BINDING SLIP
YOKE

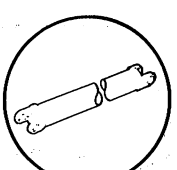

BENT
TUBE

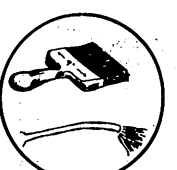

EXCESSIVE
PAINT OR
UNDERCOATING
ON TUBE

REPAIR OR REPLACE SHAFT → ROAD TEST **2** → **OK** → **7**

REPAIR OR REPLACE SHAFT → ROAD TEST **2** → ~~OK~~ → STOP → **7**

STEP

SEQUENCE

RESULT

7

CHECK FRONT AXLE PINION AND TRANSFER CASE YOKE RUNOUT USING TOOL J-24649-1

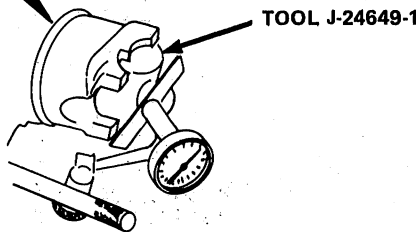

TOOL J-24649-1

MAXIMUM ALLOWABLE RUNOUT AT EITHER YOKE IS 0.006 (0.15 mm)

* REPLACEMENT YOKE RUNOUT SHOULD BE CHECKED ALSO.

IF RUNOUT IS 0.007 OR MORE, REINDEX YOKE, AND RECHECK RUNOUT. REPLACE YOKE IF REINDEXING DOES NOT CORRECT RUNOUT.* REINSTALL PROP SHAFT.

ROAD TEST

2

OK

OK

OK

STOP

8

8

8

CHECK REAR PROPELLER SHAFT RUNOUT USING DIAL INDICATOR.

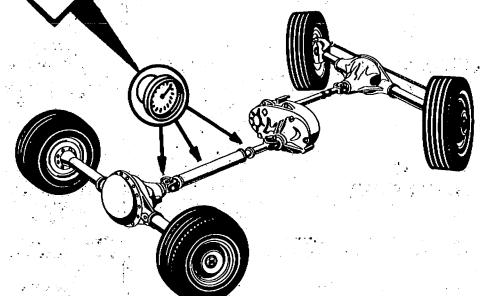

MAXIMUM ALLOWABLE RUNOUT OF SHAFT IS .015 (INCHES) TOTAL INDICATOR RUNOUT AT ENDS AND CENTER OF SHAFT. AT SHAFT ENDS, MEASURE RUNOUT 3 INCHES FROM SHAFT WELD SEAMS.

REINDEX SHAFT 180° AND RECHECK RUNOUT.

REPLACE SHAFT

ROAD TEST

2

OK

OK

OK

STOP

9

9

STEP

SEQUENCE

RESULT

9 CHECK REAR AXLE PINION UPWARD ANGLE AND ENGINE DOWNWARD ANGLE USING MAGNETIC BASE PROTECTOR

REAR AXLE PINION ANGLE MUST BE $\frac{1}{2}^{\circ}$ TO $1\frac{1}{2}^{\circ}$ (1° PREFERRED) BELOW ENGINE ANGLE. USE APPROPRIATE SHIMS TO CORRECT ANGLE

ADJUST ANGLES AS NEEDED

ROAD TEST

2

OK → **10**

OK → STOP

OK → **10**

10 CHECK REAR PROPELLER SHAFT OPERATION

1. REMOVE FRONT PROPELLER SHAFT (ALIGN MARK SHAFT AND AXLE YOKES FOR ASSEMBLY REFERENCE).
2. ROAD TEST WITH QUADRA-TRAC IN 4H-LOCK AND MODELS 208 AND 300 IN 4H.

ROAD TEST

2

VIBRATION GONE OR NOTICEABLY REDUCED → OK → **11**

NO CHANGE IN VIBRATION LEVEL → OK → **12**

11 CHECK FRONT PROPELLER SHAFT CONDITION

WORN, BINDING BRINELLED U-JOINT

WORN, LOOSE BINDING SLIP YOKE

BENT TUBE

EXCESSIVE PAINT OR UNDERCOATING ON TUBE

REPAIR OR REPLACE SHAFT

ROAD TEST

2

OK → **12**

OK → STOP

OK → **13**

STEP

SEQUENCE

RESULT

12  CHECK REAR AXLE PINION AND TRANSFER CASE YOKE RUNOUT USING TOOL J-24649-1

TOOL J-24649-1

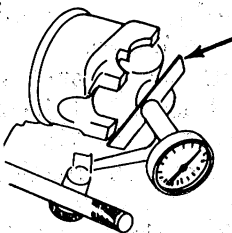

MAXIMUM ALLOWABLE RUNOUT AT EITHER YOKE IS 0.006 (0.15 mm)

* REPLACEMENT YOKE RUNOUT SHOULD BE CHECKED ALSO

IF RUNOUT IS 0.007 OR MORE; REINDEX YOKE AND RECHECK RUNOUT. REPLACE YOKE IF REINDEXING DOES NOT CORRECT RUNOUT. * REINSTALL PROP SHAFT.

ROAD TEST

2

OK

~~OK~~

~~OK~~

STOP

13

13  CHECK FRONT PROPELLER SHAFT RUNOUT USING DIAL INDICATOR

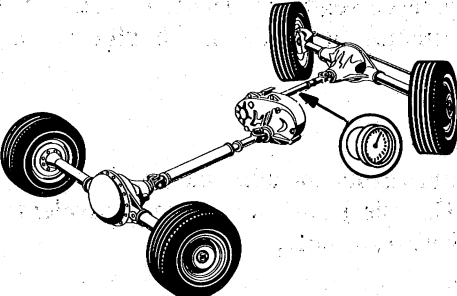

MAXIMUM ALLOWABLE RUNOUT OF SHAFT IS .015 (INCHES) TOTAL INDICATOR RUNOUT AT ENDS AND CENTER OF SHAFT. AT SHAFT ENDS, MEASURE RUNOUT 3 INCHES FROM SHAFT WELD SEAMS.

REINDEX SHAFT 180° AND RECHECK RUNOUT

OK

~~OK~~

~~OK~~

REPLACE SHAFT

ROAD TEST

2

OK

~~OK~~

STOP

14

14  CHECK FRONT AXLE PINION AND FRONT PROPELLER SHAFT ANGLES USING MAGNETIC BASE PROTECTOR

FRONT AXLE PINION ANGLE MUST BE ½° TO 1½° (1° PREFERRED) ABOVE FRONT PROPELLER SHAFT ANGLE. USE APPROPRIATE SHIMS TO OBTAIN CORRECT ANGLE

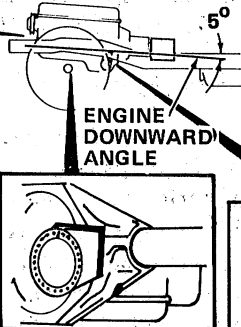

ENGINE DOWNWARD ANGLE

NOTE: Front axle pinion angle is measured using same procedure as rear axle pinion angle. Front propeller shaft angle is measured by placing protractor on front driveshaft. [Do not use engine downward angle as base for adjusting front axle pinion angle.] Record readings.

ROAD TEST

2

STOP

UNIVERSAL JOINT ANGLE MEASUREMENT AND ADJUSTMENT

When torque is transmitted through single cardan universal joints operating at an angle, the rotating speeds of the driving and driven yoke will differ. In operation, the driving yoke rotates at a constant speed while the driven yoke speeds up and slows down twice every revolution.

This difference in driven yoke rotating speed is proportional to the operating angle of the universal joint. In effect, the greater the universal joint operating angle, the greater the speed fluctuation of the driven yoke.

If fluctuation is excessive, driveline vibration will occur. As a result, the universal joint operating angles must be controlled to minimize this effect.

On some Jeep models with Quadra-Trac, an incorrect rear propeller shaft universal joint angle will generate an audible-type vibration. The vibration occurs as a constant booming or drone-like sound most noticeable in the 40 to 60 mph (64 to 97 km/h) speed range.

If a vehicle exhibits this condition, the rear propeller shaft universal joint and engine angles must be checked. If the angles are not within specified limits, shims must be installed between the rear axle spring pads and rear spring to correct the angles. Shims are available in one, two and three degree increments for this purpose. The angle measurement and correction procedure is as follows:

- (1) Place vehicle on level surface.
- (2) Measure engine downward angle as follows:
 - (a) Position protractor on left side of engine block at transmission mounting ear. Place protractor in fore and aft direction. Use mirror to view protractor if necessary.
 - (b) Record engine downward angle, remove protractor and proceed to next step.
- (3) Measure pinion upward angle as follows:
 - (a) Place protractor on left side of rear axle housing on flat machined surface of housing that is next to welded plug. Be sure this surface is free of weld flash.
 - (b) Record pinion upward angle, remove protractor and proceed to next step.
- (4) If pinion upward angle is one degree less than engine downward angle, pinion angle is within specified limits. Check for other causes of vibration.
- (5) If pinion upward angle is greater than engine downward angle by more than one degree, pinion angle must be adjusted as follows.

EXAMPLE: If the engine angle measures 5 degrees downward and the pinion angle measures 7 degrees upward, the pinion angle must be adjusted downward 3 degrees. This changes the pinion downward angle to 4 degrees which is the required one degree less than the engine downward angle.

- (6) Adjust pinion angle as outlined in following steps.

- (7) Raise rear of vehicle and place support stands under frame rails.

- (8) Position hydraulic jack under axle housing and raise jack just enough to support weight of axle.

- (9) Remove rear wheels.

- (10) Loosen rear spring U-bolt nuts.

- (11) Install appropriate degree tapered shim between spring and axle spring pad as follows:

- (a) On vehicles with spring mounted above axle, if angle must be adjusted downward, install shim so thickest end is facing front of vehicle. However, if angle must be adjusted upward, install shim so thickest end is facing rear of vehicle.

- (b) On vehicles with spring mounted below axle, if angle must be adjusted downward, install shims so thickest end is facing rear of vehicle. However, if angle must be adjusted upward, install shims so thickest end is facing front of vehicle.

- (12) Tighten U-bolt nuts to 100 foot-pounds (135 N•m) torque.

- (13) Install rear wheels.

- (14) Remove support stands and lower vehicle.

LUBRICATION

The propeller shaft slip yoke and universal joints on all Jeep vehicles require periodic lubrication. Refer to the Maintenance Schedule in Chapter B for specific details.

Lubricant Type

When lubricating the slip yokes and universal joints, use Jeep Chassis Lubricant or an equivalent lithium-base chassis grease only.

Lubrication Intervals

On Cherokee, Wagoneer and Truck models, the slip yokes and universal joints must be lubricated at 12,500 mile (20 000 km) or 12.5 month intervals in normal service and at 5,000 mile (8 000 km) or 5 month intervals for heavy-duty service.

On CJ and Scrambler models, the slip yoke and universal joints must be lubricated at 5,000 mile (8 000 km) or 5 month intervals in normal service and at 2,500 mile (4 000 km) or 2.5 month intervals for heavy-duty service.

Lubrication Fittings

Externally mounted lubrication fittings are located in the slip yokes and single cardan universal joint spiders for lubrication purposes.

Double cardan universal joints have special ball and spring fittings that require a needle-type lube gun nozzle adapter (fig. 2E-7). When lubricating double cardan joints, use Lube Fitting Adapter J-25512-2 (fig. 2E-8) or Alemite Lube Fitting Adapter 6783, or equivalent.

CAUTION: It is important that the recommended lubricant and lubrication schedule be adhered to. Failure to comply with lubrication requirements may result in premature wear of propeller shaft components.

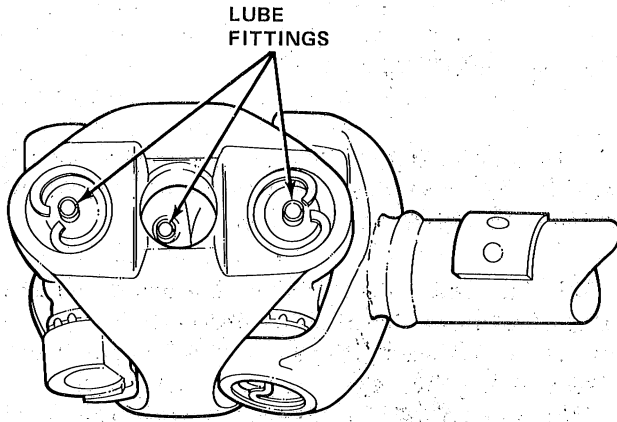

90143

Fig. 2E-6 Double Cardan Joint Lube Fittings

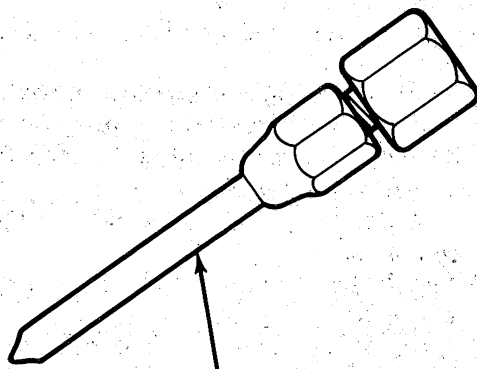

TOOL J - 25512 - 2

90144

Fig. 2E-7 Double Cardan Lube Fitting Adapter

PROPELLER SHAFT SERVICE

Removal—Front Shaft

- (1) Raise vehicle.
- (2) Mark propeller shaft yokes, transfer case output shaft yoke, and axle yoke for assembly alignment reference.
- (3) Disconnect propeller shaft at axle and transfer case yokes and remove shaft.

Installation—Front Shaft

- (1) Align reference marks on propeller shaft and yokes and install propeller shaft.
- (2) Tighten clamp strap bolts to 15 foot-pounds (20 N•m) torque.
- (3) Lower vehicle.

Removal—Rear Shaft

- (1) Raise vehicle.
- (2) Mark propeller shaft, transfer case yoke or flange, and axle yoke for assembly alignment reference.
- (3) Disconnect shaft at transfer case and axle yokes and remove shaft.

Installation—Rear Shaft

- (1) Align reference marks on propeller shaft yokes and install shaft.
- (2) Tighten clamp strap bolts to 15 foot-pounds (20 N•m) torque.
- (3) Lower vehicle.

UNIVERSAL JOINT SERVICE

The single and double cardan universal joints are serviced as assemblies. Both universal joint types can be disassembled for inspection and replacement purposes.

Disassembly—Single Cardan Joint

- (1) If slip yoke universal joint is to be replaced, paint alignment marks on slip yoke and propeller shaft for assembly reference and remove slip yoke from shaft.
- (2) Remove loose bearing caps from spider and apply penetrating oil to bearing caps seated in shaft yoke.
- (3) Mount propeller shaft or slip yoke in vise.

CAUTION: Do not clamp the propeller shaft tube in the vise. Clamp only the forged portion of the slip yoke or propeller shaft yoke in the vise. Also, to avoid distorting either of the yokes, do not overtighten the vise.

- (4) Remove bearing cap retainers (fig. 2E-4). Tap ends of bearing caps with hammer to relieve pressure on retainers if necessary.
- (5) Reposition shaft in vise so yoke is supported on vise jaws.
- (6) Tap end of one bearing cap with hammer until opposite bearing cap is driven out of yoke.
- (7) Reposition shaft yoke in vise and tap exposed end of spider to drive remaining bearing cap out of yoke.
- (8) Remove spider from yoke.

Cleaning and Inspection

Clean the yoke bearing cap bores with solvent and a wire brush. Be sure to remove all rust, corrosion or dirt. Wash the bearing caps, bearings and spiders in solvent and wipe them dry with a shop cloth.

Inspect the bearing caps, needle bearings and bearing surfaces of the spider for evidence of brinelling, excessive wear, flat spots, scoring or cracks. Replace the complete assembly if any part exhibits these conditions.

Assembly—Single Cardan Joint

(1) Lubricate all needle bearings, bearing caps and bearing surfaces of spider with chassis grease. Also apply thin film of grease to exterior surface of bearing caps.

(2) Install bearing cap seals on spider.

(3) Install one bearing and needle bearing assembly part-way into shaft yoke.

(4) Position spider in shaft yoke and install opposite bearing cap and needle bearing assembly in yoke.

(5) Support yoke on vise jaws and seat both bearing caps in yoke using hammer.

(6) Install bearing cap retainers. Tap ends of bearing caps to seat caps fully if retainers are difficult to install.

(7) Install two remaining bearing cap and needle bearing assemblies on spider. Use rubber band or tape to retain these caps on spider until shaft is to be installed.

Disassembly—Double Cardan Joint

NOTE: The socket yoke, ball, spring, needle bearings, retainer and thrust washers are serviced as an assembly only (fig. 2E-6). When servicing the double cardan joint, do not disassemble these components. If any one component is damaged, replace the assembly.

(1) Remove all bearing cap retainers.

(2) Mark bearing caps, spiders, propeller shaft yoke, link yoke and socket yoke for assembly alignment reference.

(3) Remove bearing caps attaching front spider to propeller shaft yoke as follows (fig. 2E-5):

(a) Use 5/8 socket as bearing cap driver and 1-1/16 socket as bearing cap receiver.

(b) Place 5/8 socket on one bearing cap and 1-1/16 socket over opposite bearing cap.

(c) Mount assembly in vise so vise jaws bear directly against sockets positioned on bearing caps.

(d) Tighten vise to press first bearing cap out of link yoke.

(e) Loosen vise, reposition sockets, and press opposite bearing cap out of link yoke.

(4) Disengage propeller shaft yoke from link yoke.

(5) Remove bearing caps attaching front spider to propeller shaft yoke as outlined in step (3).

(6) Remove front spider from yoke.

(7) Remove bearing caps attaching rear spider to link yoke as outlined in step (3) and remove rear spider and socket yoke from link yoke.

Cleaning and Inspection

Clean the yoke bearing cap bores with solvent and a wire brush. Be sure to remove all rust, dirt and corrosion from the bores. Wash the universal joint components in solvent and wipe them dry with a shop cloth.

Inspect all bearings and bearing surfaces for excessive wear, galling, brinelling, scoring, flat spots or cracks. Inspect the yokes for distortion, cracks or worn bearing cap bores. Replace the complete assembly if any component exhibits these conditions.

Assembly—Double Cardan Joint

NOTE: When assembling the universal joint, be sure to align the spiders and yokes according to the reference marks made during disassembly.

(1) Lubricate all bearings and bearing contact surfaces with lithium-base chassis grease.

(2) Install bearing caps on transfer case yoke ends of rear spider. Secure caps to spider using tape.

(3) Assemble socket yoke and rear spider.

(4) Position rear spider in link yoke and install bearing caps. Press caps into yoke using 5/8 socket. Be sure to press caps into yoke bores far enough to expose bearing cap retainer grooves.

(5) Install rear spider-to-link yoke bearing cap retainers.

(6) Position front spider in propeller shaft yoke and install bearing caps. Press caps into yoke using 5/8 socket. Be sure to press caps into yoke bores far enough to expose bearing cap retainer grooves.

(7) Install front spider-to-propeller shaft yoke bearing cap retainers.

(8) Install thrust washer and socket spring in ball socket bearing bore, if removed.

(9) Install thrust washer on ball socket bearing boss (located on propeller shaft yoke), if removed.

(10) Align ball socket bearing boss on propeller shaft yoke with ball socket bearing bore and insert boss into bore.

(11) Align front spider with link yoke bearing cap bores and install bearing caps. Press caps into yoke using 5/8 socket. Be sure to press caps into yoke bores far enough to expose bearing cap retainer grooves.

(12) Install front spider-to-link yoke bearing cap retainers.

SPECIFICATIONS

Universal Joint Angle Chart

	Front		Rear	
	OK Range	Set-To	OK Range	Set-To
Cherokee Wagoner Truck	6°-8°	7°	4°-6°	5°
CJ/Scrambler	3°-5°	4°	4°-6°	5°

Torque Specifications

Service Set-To Torques should be used when assembling components. Service In-Use Recheck Torques should be used for checking a pre-tightened item.

	USA (ft-lbs)		Metric (N·m)	
	Service Set-To Torque	Service In-Use Recheck Torque	Service Set-To Torque	Service In-Use Recheck Torque
Pinion Yoke Nut:				
Model 30-44 Axle	210	200-220	285	271-298
Model 60 Axle	260	250-270	352	339-366
AMC—Jeep Axle				
			Add 5 in-lbs. (0.56 N·m) torque measured at disassemble. Refer to Pinion Seal and Yoke Replacement, Chapter 2F- AMC—Jeep Axle.	
Universal Joint Clamp Strap Bolt	15	13-18	20	18-24

All Torque values given in foot-pounds and newton-meters with dry fits unless otherwise specified.

80336

Tools

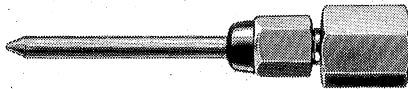

**LUBE FITTING
ADAPTER TOOL
J-25512-2**

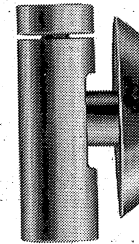

**J-24649-1
YOKE RUNOUT
GAUGE**

